

#25 is THREE
1/16" flat
glued to-
gether and
tapered.

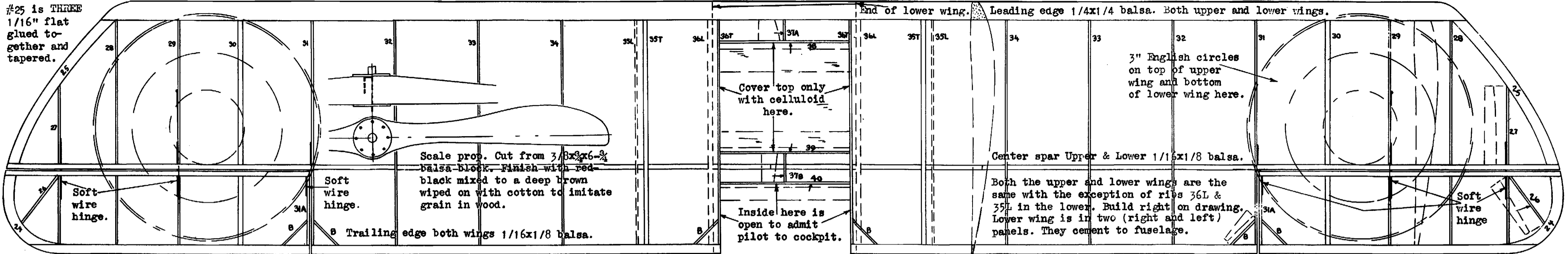

To make the ailerons fit better into the wing, make them at the same time that the wing is made leaving the trailing edge in one piece and with 1/32 spacers in between the spars. When dry, cut the trailing edge and spacers and cement in the iron wire hinges.

NOTE: Cut away the paper from all joints, as the paper will not hold as well as the wood to wood joint will.

Brace wire between ailerons. This on the real ship moves the controls in coordination with each other.

Brace wires are ordinary thread sewed in with a fine needle. Bead needles, used for stringing beads, are best, being long and thin. Cement all joints.

Study the drawing, pictures and notes for information in building the model. Check them with each other to make them clear in your mind. You will find that the "CAMEL" in one of the PEERLESS line to construct, and one of the best flyers.

Paper disc. Cut "V" and join parts with butt joint. Paste a strip behind out to hold it, and cement it on wheel. Color line is sketched or drawn with compass.

Cylinders of 3/8" sq. Sand round, wrap with thread for vanes and cut as in side view.

Tie cross-brace thus

Tube sight 1/8" rounded.

Air speed indicator. Position on right strut.

CONSTRUCTION HINTS
The fuselage. First step is to cement balsa piece #10 to the bottom longeron where shown in the side view. Second, cement in the vertical upright 1/16" sq. pieces that lie behind #2B and 3B to this. Use a flat board. Cement the top longeron to these, then the rest of the upright 1/16"sq. Make two sides alike. Cement the long cross pieces near the cockpit first, then the smaller ones toward the tail. See top view. Lastly cement on the formers. Cut these from the printed wood exactly on the fine printed lines. PEERLESS goes to great expense to get the lines of this drawing and the printed wood fine so that greater exactness may be attained.
Wings. Cut the ribs from the printed sheet, and sand them to the printed lines. Cement them, using the plan as a guide to the spar, then the leading edge. Lastly the trailing edge. True up evenly by sanding. See notes on wing.
Tail surfaces. These are made of 1/16" sq. and are constructed on the drawing. Don't forget the small brace blocks for the brace wires.
COVERING. Cover the model when wood parts are finished in small sections at a time, that is between two formers on the fuselage and half the wing with tips separate. Use the Tissue Cement in the kit as the adhesive. Apply with brush. Trim paper with razor

An accurate, authentic 3/4" scale model.
DESIGNED BY *Lo Howell*
For The PEERLESS MODEL AIRPLANE CO. 1934.

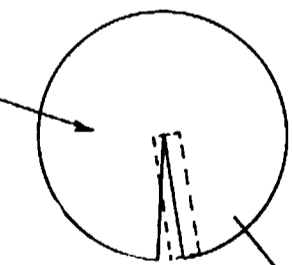

2 pieces of 1/16" flat balsa. Cement on either side of axle.

String omitted to show manner in which wire parts are bent. Axle held thus and shock absorber made in this way are almost identical with the real "Camel".

Flying notes. Power the model with 6 to 8 strands of 1/8" flat rubber. Wind not over 100 turns by hand. Test flight for balance with a few turns in a large open area. Ailerons and tail controls help trim the ship.



Bend small end of blade and cement well into hub. Camber the blades 1/8" for better flights

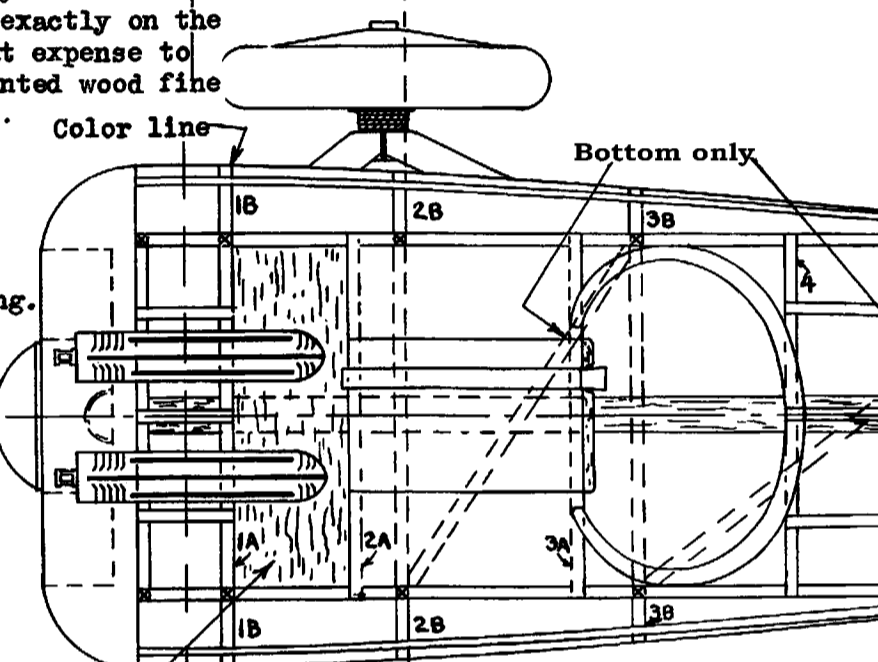
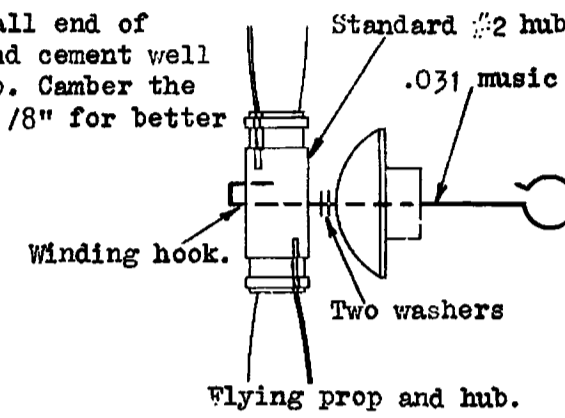

5/8x2" balsa. Shape after it is cemented in.

Machine guns are 1/4" sq. rounded. Dope black. Vents are razor cuts. Grooves are pencil lines indented.

Fill in around cockpit with scrap 1/16" fl. Padding is 1/16" fl. cut across the grain and bend around rim. Sand half round and paint black or brown.

Color scheme: Fuselage, wings and tail surfaces YELLOW. Nose to color line indicated and struts, RED. Tires and guns, etc, BLACK. Prop and padding as indicated of brown. Wheels have unique bi-color scheme. See plan.

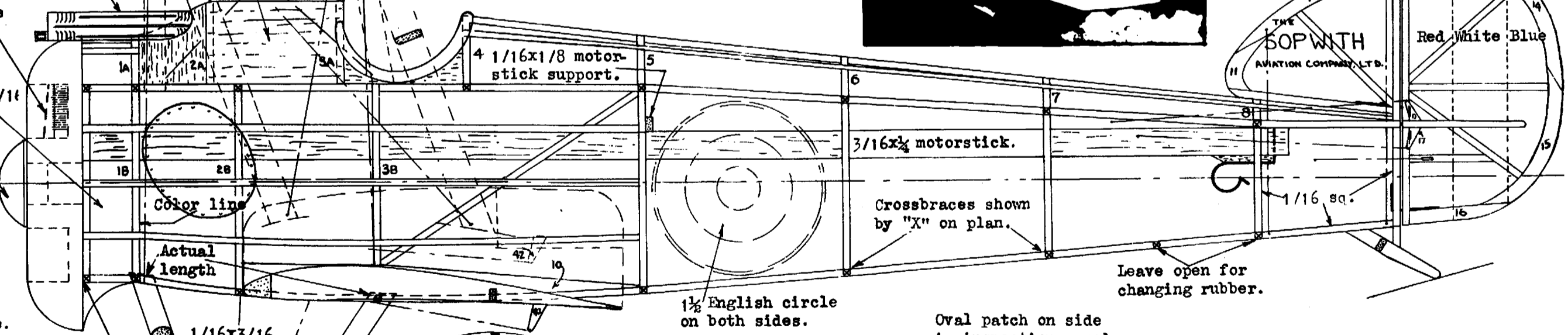

No formers here. Stringers butt against cowl.

String omitted to show manner in which wire parts are bent. Axle held thus and shock absorber made in this way are almost identical with the real "Camel".

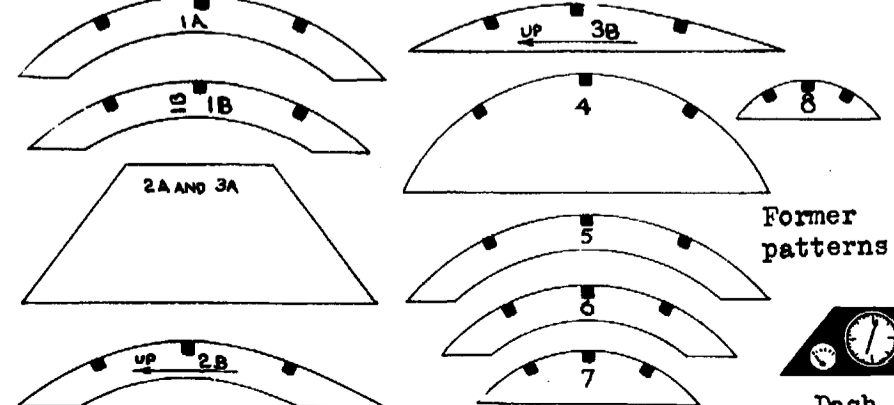

SOPWITH CAMEL
COPYRIGHT 1934 by
THE PEERLESS MODEL AIRPLANE COMPANY
QUALITY MODEL AIRPLANE KITS & SUPPLIES
15533 MADISON AVE. LAKEWOOD, OHIO, U. S. A.
Scanned and restored November 2010 pd1
All rights reserved